

HFE2500 Series

2500W 1U Hot Swap Front End Power Supplies

- 29.2W/in³ power density
- 1U rackmount containing up to 4 units
- Internal ORing MOSFET & Current Share
- Up to 10,000W in 1U rack
- PMBus™ (I²C) and LAN options



Key Market Segments & Applications

Power for Distributed Power Architecture Industrial Automation



Industrial



Test



Broadcast



Comm

HFE2500 Features and Benefits

Features

- 1U high
- Internal ORing MOSFET & Current Share
- Full array of signals available

Benefits

- Utilizes less system space
- Suitable for N+1 redundancy
- Easier system monitoring including PMBus™ and LAN

Specifications

MODELS		HFE2500
ITEMS		
Input Voltage Range	(2) VAC	85 - 265VAC, 47 - 63Hz. See model selector for power derating
Input Current (Max) 100/230VAC	A	17 / 12A
Inrush Current	A	<50A
Power Factor Correction	-	Meets EN61000-3-2, PF > 0.98 at full load
Temperature Coefficient	%/°C	<0.02%/°C
Overcurrent Protection	%	105 - 115%. Programmable by external voltage (0-5V)
Overvoltage Protection	(1) %	110% ±3% (Tracking). Cycle AC to reset or utilize Remote On/Off
Overtemperature Protection	(1) -	Shutdown with automatic reset. Warning signal provided
Hold-up time	ms	>10ms, 115/230VAC Input, 80% loading
Leakage Current	mA	< 0.75 / 1.5mA, 100 / 230VAC, 60Hz
Remote Sense Compensation	-	HFE2500-12: 0.25V / Wire, HFE2500-24: 0.5V, -48 1V / Wire
Indicators	-	AC OK: Green LED, DC OK / Fail: Green / Red LED
Remote On/Off	-	Unit ON: 0 - 0.6V or short, OFF: 2 - 15V or open circuit
Parallel Operation	(1) -	Yes, single wire current share, 90% accuracy, up to 8 units
AC Fail Signal	-	Open Collector, ON when AC is within 85 - 270VAC
DC Good Signal	-	Open Collector, ON when output is above 85 to 95% of setpoint (tracking)
Remote Adjust	(1) -	By either external 0 - 5V signal or 1k potentiometer
I ² C Interface	(1) -	Isolated from output, Add suffix /S, PMBus compatible
Auxiliary Output	-	11.2 - 12.5V, 0.5A, 240mV ripple and noise
Operating Temperature	°C	-10°C to +70°C, derate 2%/°C from 50°C to 60°C, 2.5%/°C from 60°C to 70°C
Storage Temperature	°C	-30°C to +85°C
Humidity (Non condensing)	%RH	Operating: 10 - 90%RH, Storage: 10 - 95%RH
Cooling	-	Two variable speed internal fans, airflow exits across input/output connector
Withstand Voltage	-	I/P to O/P 3kVAC, I/P to Grnd 2kVAC, O/P to Grnd: HFE2500-12, -24V 500VAC, HFE2500-48 2250VDC
Isolation Resistance	MΩ	>100MΩ at 25°C & 70%RH, Output to Ground 500VDC
Vibration (Basic transportation)	-	Meets IEC60068-2-64
Shock (Basic transportation)	-	Meets IEC60068-2-27
Safety Agency Certifications	-	UL60950-1, EN60950-1, CE Mark
Line Dip	-	Complies with SEMI F47 (200VAC line only)
Conducted and Radiated EMI	-	EN55022 & FCC part 15: Conducted class B, Radiated class A
Immunity	-	IEC61000-4-2 (lv 2,3), -3 (lv 2), -4 (lv 3), -5 (lv 3,4), -6 (lv 2), -8 (lv 4), -11
Size (W x H x D)	mm	Power Supply: 107 x 41 x 325, Rack: 445 x 44 x 402
Weight	g	Power Supply: 2100g, Rack: 5000g
Warranty yrs	Yrs	3

(1) See installation manual for detailed specifications & test methods (2) Derate linearly 1.3%/V from 100VAC to 85VAC input

Model Selector						
Model	Output Voltage	Adjust Range (1)	Max Current (Vin>170VAC)	Max Power (Vin>170VAC)	Max Current (100<Vin<170VAC)(2)	Max Power (100<Vin<170VAC)(2)
HFE2500-12	12V	9.6 - 13.2V	200A	2400W	125A	1500W
HFE2500-12/S	12V	9.6 - 13.2V	200A	2400W	125A	1500W
HFE2500-24	24V	19.2 - 29V	104A	2496W	62.5A	1500W
HFE2500-24/S	24V	19.2 - 29V	104A	2496W	62.5A	1500W
HFE2500-48	48V	38.4 - 58V	52A	2496W	31.25A	1500W
HFE2500-48/S	48V	38.4 - 58V	52A	2496W	31.25A	1500W

Model	Load Reg	Line Reg	Ripple & Noise	Efficiency (%) (3)	ƒC
HFE2500-12	60mV	30mV	240mV	90 / 92%	-
HFE2500-12/S	60mV	30mV	240mV	90 / 92%	Yes
HFE2500-24	120mV	60mV	240mV	90 / 92%	-
HFE2500-24/S	120mV	60mV	240mV	90 / 92%	Yes
HFE2500-48	240mV	120mV	480mV	91 / 93%	-
HFE2500-48/S	240mV	120mV	480mV	91 / 93%	Yes

(3) At 75% load, 115 / 230VAC input

Model	Description	Maximum Rack Current
HFE2500-S1U	Four slot 19" rack, IEC320-C20 input connector	320A each side (640A total)
HFE2500-S1U-TB	Four slot 19" rack, Terminal Block input connector	320A each side (640A total)
HFE2500/BP	One slot blanking panel, two provided with each rack	-
HFE2500-LAN	Plug in LAN module. Takes up one rack slot. For use with /S models only	-

Outline Drawing HFE2500

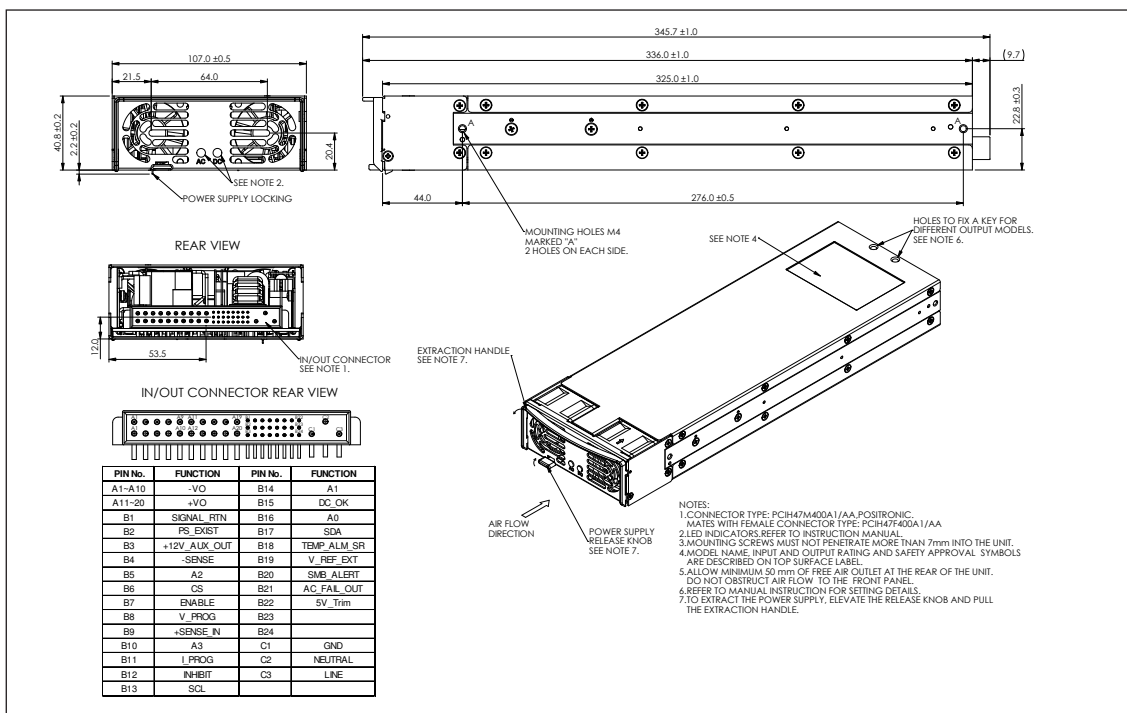

Outline Drawing HFE2500 - S1U

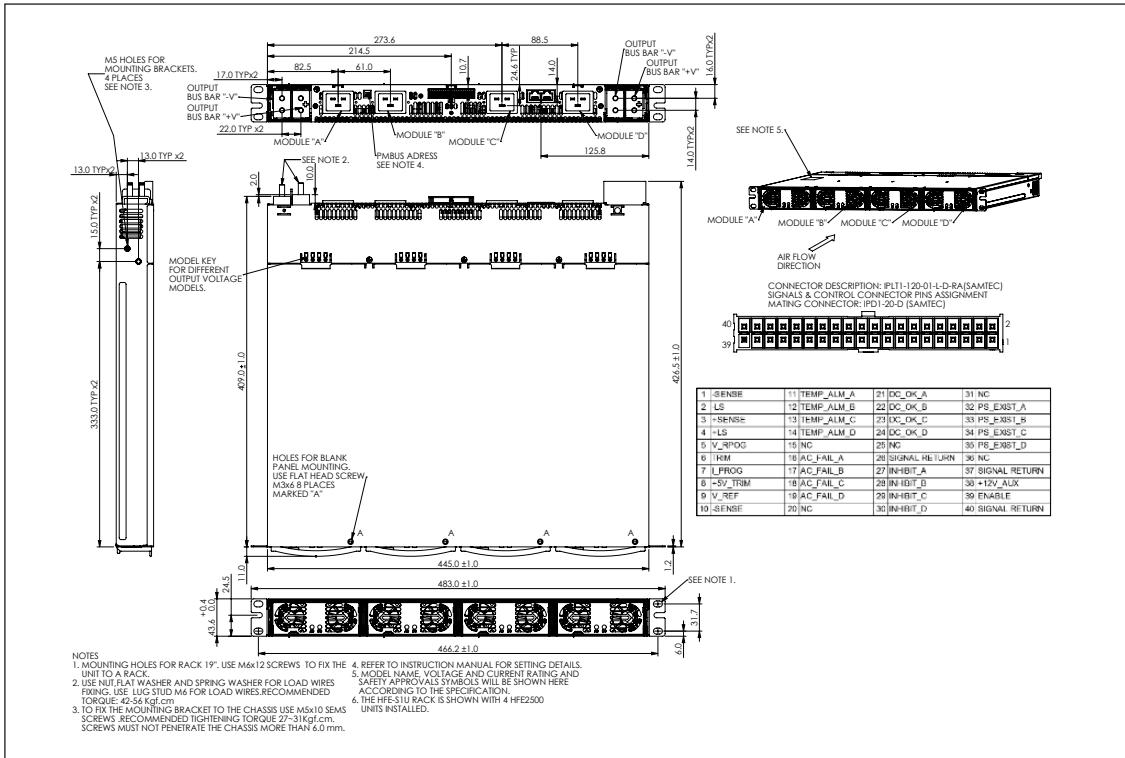

Outline Drawing HFE2500 - S1U - TB

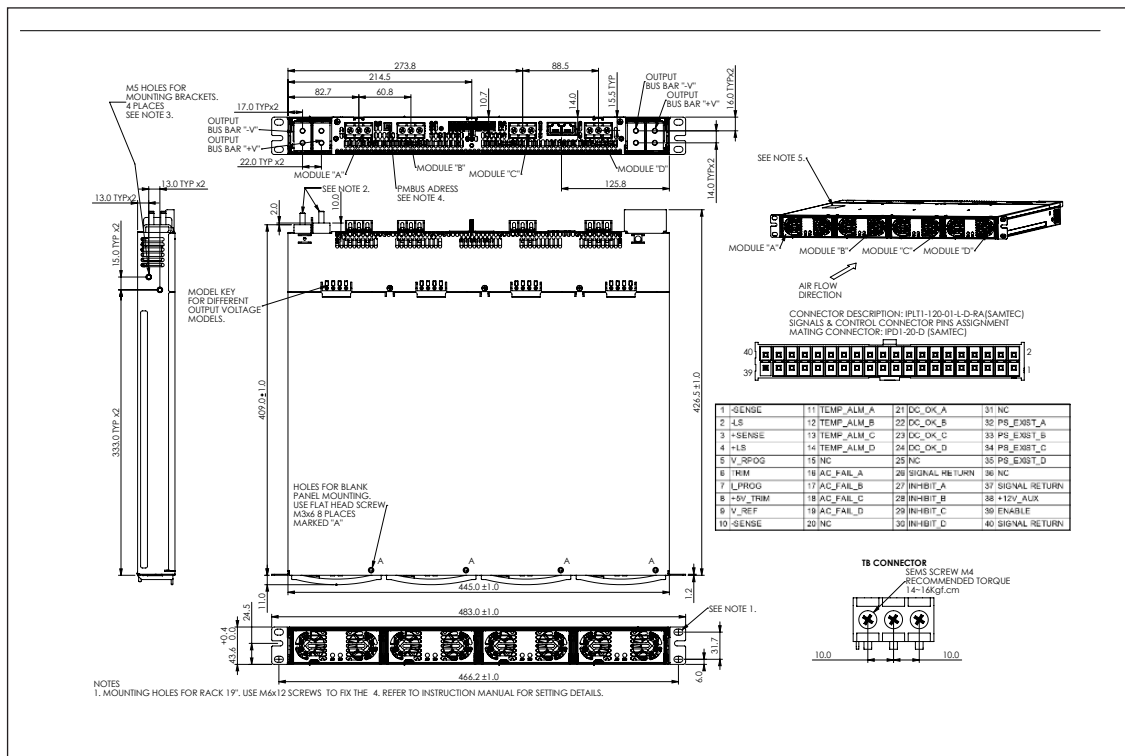

Outline Drawing HFE2500- LAN

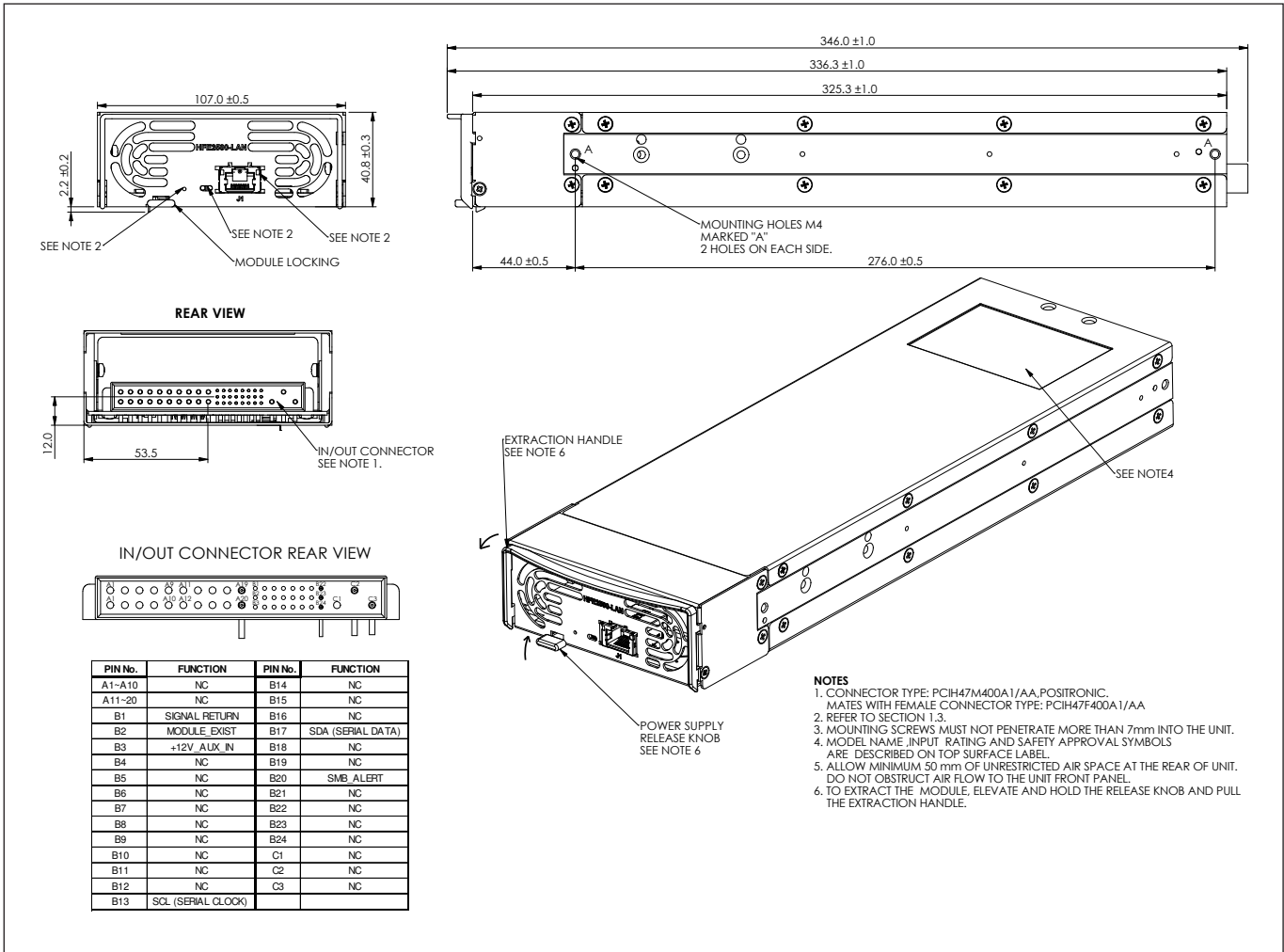



TDK-Lambda France SAS

3 Avenue du Canada
 Parc Technopolis
 Bâtiment Sigma
 91940 les Ulis
 France
 Tel: +33 1 60 12 71 65
 Fax: +33 1 60 12 71 66
france@fr.tdk-lambda.com
www.fr.tdk-lambda.com



Italy Sales Office

Via dei Lavoratori 128/130
 20092 Cinisello Balsamo (MI)
 Italy
 Tel: +39 02 61 29 38 63
 Fax: +39 02 61 29 09 00
info.italia@it.tdk-lambda.com
www.it.tdk-lambda.com



Netherlands

info@nl.tdk-lambda.com
www.nl.tdk-lambda.com



TDK-Lambda Germany GmbH

Karl-Bold-Strasse 40
 77855 Achern
 Germany
 Tel: +49 7841 666 0
 Fax: +49 7841 5000
info.germany@de.tdk-lambda.com
www.de.tdk-lambda.com



Austria Sales Office

Aredstrasse 22
 2544 Leobersdorf
 Austria
 Tel: +43 2256 655 84
 Fax: +43 2256 645 12
info@at.tdk-lambda.com
www.de.tdk-lambda.com



Switzerland Sales Office

Bahnhofstrasse 50
 8305 Dietlikon
 Switzerland
 Tel: +41 44 850 53 53
 Fax: +41 44 850 53 50
info@ch.tdk-lambda.com
www.de.tdk-lambda.com



Nordic Sales Office

Haderslevvej 36B
 DK-6000 Kolding
 Denmark
 Tel: +45 2911 9556
info@dk.tdk-lambda.com

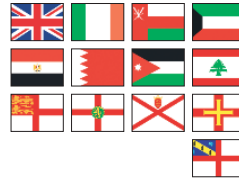

TDK-Lambda UK Ltd.

Kingsley Avenue
 Ilfracombe
 Devon EX34 8ES
 United Kingdom
 Tel: +44 (0) 12 71 85 66 66
 Fax: +44 (0) 12 71 86 48 94
powersolutions@uk.tdk-lambda.com
www.uk.tdk-lambda.com



TDK-Lambda Ltd.

Kibbutz
 Givat Hashlosha 48800
 Israel
 Tel: +9 723 902 4333
 Fax: +9 723 902 4777
info@tdk-lambda.co.il
www.tdk-lambda.co.il



C.I.S.

Commercial Support:
 Tel: +7 (495) 665 2627
Technical Support:
 Tel: +7 (812) 658 0463
info@tdk-lambda.ru
www.tdk-lambda.ru

Local Distribution

