

1 Watt

- Single Output
- SMD Package
- Industry Standard Pinout
- Operating Temperature -40 °C to +105 °C
- 1500 VDC Isolation, 3000 VDC Option
- 3 Year Warranty



Dimensions:

ISE:
0.500 x 0.44 x 0.285" (12.7 x 11.2 x 7.25 mm)

Models & Ratings

Input Voltage	Output Voltage	Output Current	Input Current ⁽²⁾		Maximum Capacitive Load	Efficiency ⁽³⁾	Model Number
			No Load	Full Load			
2.97-3.63 V	3.3 V	303 mA	25 mA	404 mA	220 µF	72%	ISE0303A ⁽¹⁾
	5 V	200 mA	25 mA	404 mA	220 µF	74%	ISE0305A ⁽¹⁾
	12 V	84 mA	25 mA	404 mA	220 µF	80%	ISE0312A
	15 V	67 mA	25 mA	404 mA	220 µF	80%	ISE0315A
	24 V	42 mA	25 mA	404 mA	220 µF	80%	ISE0324A
4.5-5.5 V	3.3 V	303 mA	20 mA	250 mA	220 µF	74%	ISE0503A ⁽¹⁾
	5 V	200 mA	20 mA	250 mA	220 µF	80%	ISE0505A ⁽¹⁾
	6 V	167 mA	20 mA	250 mA	220 µF	80%	ISE0506A ⁽¹⁾
	9 V	111 mA	20 mA	250 mA	220 µF	80%	ISE0509A ⁽¹⁾
	12 V	84 mA	20 mA	250 mA	220 µF	80%	ISE0512A ⁽¹⁾
	15 V	67 mA	20 mA	250 mA	220 µF	80%	ISE0515A ⁽¹⁾
	24 V	42 mA	20 mA	250 mA	220 µF	80%	ISE0524A ⁽¹⁾
10.8-13.2 V	3.3 V	303 mA	15 mA	104 mA	220 µF	74%	ISE1203A ⁽¹⁾
	5 V	200 mA	15 mA	104 mA	220 µF	80%	ISE1205A ⁽¹⁾
	9 V	111 mA	15 mA	104 mA	220 µF	80%	ISE1209A ⁽¹⁾
	12 V	84 mA	15 mA	104 mA	220 µF	81%	ISE1212A ⁽¹⁾
	15 V	67 mA	15 mA	104 mA	220 µF	81%	ISE1215A ⁽¹⁾
13.5-16.5 V	5 V	200 mA	10 mA	82 mA	220 µF	80%	ISE1505A
	15 V	67 mA	10 mA	82 mA	220 µF	81%	ISE1515A ⁽¹⁾
21.6-26.4 V	5 V	200 mA	7 mA	52 mA	220 µF	80%	ISE2405A ⁽¹⁾
	9 V	111 mA	7 mA	52 mA	220 µF	80%	ISE2409A ⁽¹⁾
	12 V	84 mA	7 mA	52 mA	220 µF	80%	ISE2412A
	15 V	67 mA	7 mA	52 mA	220 µF	81%	ISE2415A ⁽¹⁾
	24 V	42 mA	7 mA	52 mA	220 µF	81%	ISE2424A ⁽¹⁾

Notes

1. For optional 3000 VDC isolation add suffix '-H' to end of part number e.g. ISE1224A-H.

2. Input currents measured at nominal input voltage.

3. Typical value at full load.

Mechanical Details

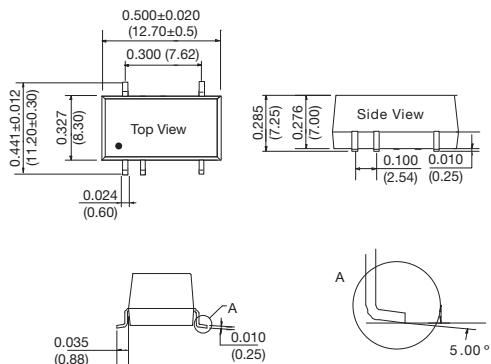

PIN CONNECTIONS	
Pin	Function
1	-Vin
2	+Vin
4	0V
5	+Vout
8	No Connection

Notes

1. All dimensions are in inches (mm)
2. Weight: 0.003 lbs (1.5 g) typical.
3. Pin diameter: 0.02 ±0.002 (0.5 ±0.005)
4. Pin pitch and length tolerance: ±0.014 (±0.35)
5. Case tolerance: ±0.02 (±0.5)

Input

Characteristic	Minimum	Typical	Maximum	Units	Notes & Conditions
Input Voltage Range	2.97		3.63	VDC	3.3 V nominal
	4.50		5.50	VDC	5 V nominal
	10.80		13.20	VDC	12 V nominal
	13.50		16.50	VDC	15 V nominal
	21.60		26.40	VDC	24 V nominal
Input Current					See Models and Ratings table
Input Reflected Ripple		15		mA pk-pk	Through 12 μ H inductor and 47 μ F capacitor
Input Surge			5	VDC for 1 s	3.3 V models
			9	VDC for 1 s	5 V models
			18	VDC for 1 s	12 V models
			21	VDC for 1 s	15 V models
			30	VDC for 1 s	24 V models
Input Filter	Capacitor				

Output

Characteristic	Minimum	Typical	Maximum	Units	Notes & Conditions
Output Voltage	3.3		24	VDC	See Models and Ratings table
Initial Set Accuracy			-7.5, +2.5	%	At 70% load
Minimum Load	10			%	
Line Regulation			± 1.2	%	Per 1% change of input voltage ($\pm 1.5\%$ for 3V3 output)
Load Regulation				%	See graph
Start Up Delay				ms	
Ripple and Noise			30/60	mV pk-pk	For models ≤ 12 V/ For 15 V & 24 V models, 20 MHz bandwidth, measured using 0.1 μ F capacitor
Transient Response			3	% deviation	Recovery to within 1% in 500 μ s for a 25% load change (5% max. deviation for 3.3 & 5 V models)
Short Circuit Protection					Continuous, with auto recovery, except 1 s max for 24 input V models
Maximum Capacitive Load			220	μ F	
Temperature Coefficient			0.02	%/ $^{\circ}$ C	

General

Characteristic	Minimum	Typical	Maximum	Units	Notes & Conditions
Efficiency					See Models and Ratings table
Isolation: Input to Output	1500			VDC	For optional high isolation versions, 3000 VDC input to output add suffix -H to model number
Switching Frequency	50		300	kHz	Full load, nominal input
Isolation Resistance	10^9			Ω	Input to output, tested at 500 VDC
Isolation Capacitance		20		pF	Input to output
Power Density			15.9	Win ³	
Mean Time Between Failure	3500			kHrs	MIL-HDBK-217F, +25 $^{\circ}$ C GB
Weight		0.003 (1.5)		lb (g)	
Recommended Solder Profile	IPC/JEDEC J-STD-020D.1				

Environmental

Characteristic	Minimum	Typical	Maximum	Units	Notes & Conditions
Operating Temperature	-40		+105	$^{\circ}$ C	Derate from 100% load at +100 $^{\circ}$ C to 80% load at 105 $^{\circ}$ C
Storage Temperature	-55		+125	$^{\circ}$ C	
Case Temperature			+115	$^{\circ}$ C	
Operating Humidity			95	% RH	Non-condensing
Cooling					Natural convection

EMC: Emissions

Phenomenon	Standard	Test Level	Notes & Conditions
Conducted	EN55022	Class B	See Application Note for Class B filter
Radiated	EN55022	Class B	See Application Note for Class B filter

EMC: Immunity

Phenomenon	Standard	Test Level	Criteria	Notes & Conditions
ESD Immunity	EN61000-4-2	3	B	
Radiated Immunity	EN61000-4-3	3 V/m	A	
EFT/Burst	EN61000-4-4	2	B	External input capacitor required, 330 μ F/100 V
Surge	EN61000-4-5	2	B	External input capacitor required, 330 μ F/100 V
Conducted Immunity	EN61000-4-6	3 V rms	A	
Magnetic Fields	EN61000-4-8	1 A/m	A	

Load Regulation

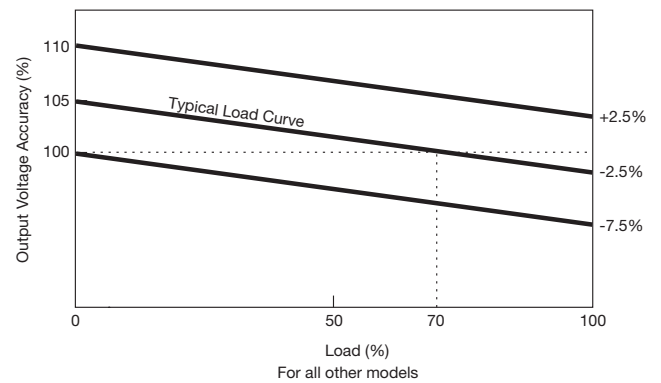
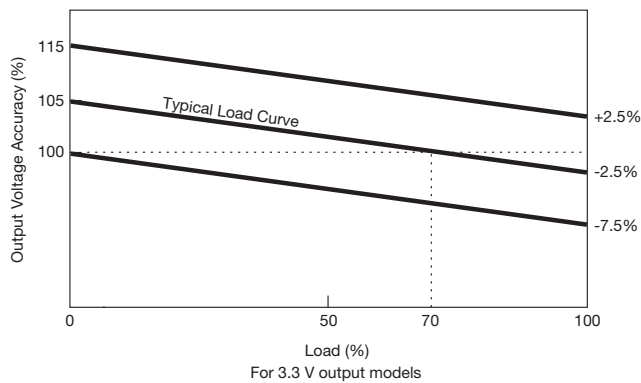

Application Note

EMI Filter for Class B Emissions

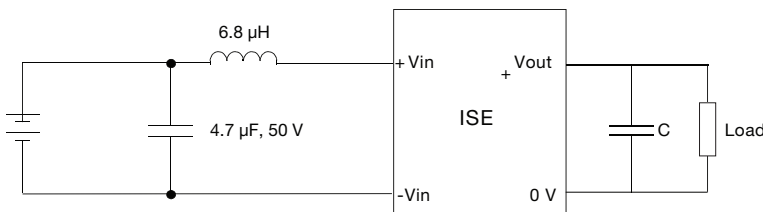

Output Voltage	C
3.3	10.00 μ F
5/6	10.00 μ F
9	4.70 μ F
12	2.20 μ F
15	1.00 μ F
24	0.47 μ F