

LS02 Series Level Sensors

- **Features:** IP68-only up to Screw in Thread, High Power Switch Option, Other Cables & Connectors
- **Applications:** Level Control, Detection and Monitoring
- **Markets:** Automotive, Appliance, HVAC/R, Test & Measurement

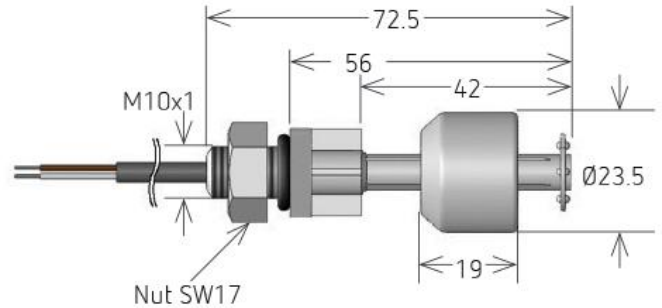

Part Description: **LS02-0X00-XX-000X**

Contact Qty	Contact Form	Switch Model	Material	Cable Length (mm)	Termination
1	A, B	66, 85	PA, PP	500, 1000, 5000	W = Stripped & Tinned

Customer Options	Switch Model		Unit
	66	85	
Contact Data			
Rated Power (max.) Any DC combination of V&A not to exceed their individual max.'s	10	100	W
Switching Voltage (max.) DC or peak AC	180	1000	V
Switching Current (max.) DC or peak AC	0.5	1.0	A
Carry Current (max.) DC or peak AC	1.25	2.5	A
Contact Resistance (max.) @ 0.5V & 50mA	150	150	mOhm

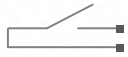
Glossary Contact Form		
Form A	NO = Normally Open Contacts SPST = Single Pole Single Throw	
Form B	NC = Normally Closed Contacts SPST = Single Pole Single Throw	
Form C	Changeover SPDT = Single Pole Double Throw	

Glossary Material	
PP: Polypropylene	For water applications and dilute acids
PA: Polyamide	For oil
NBR: Nitrile Butadiene Rubber	For oil, gasoline & in high temperatures
SS: Stainless Steel	For high temp. (>160°C)

LS02 Series Level Sensors

General Sensor Data

Materials			
Stem, nut	PA	PP	
Float	PA	PP	NBR
Seal	Nitrile Rubber		
Cable Specifications	Low Voltage (66 Switch Model)	High Voltage (85 Switch Model)	
Cross Section (mm ²)	0.14	0.25	
Cable Material	PVC		
Packing	Bulk		

LS02 Reed Sensor



Environmental Data

		Unit
Shock Resistance (max.) 1/2 sine wave duration 11ms	50	g
Vibration Resistance (max.)	20	g
Operating Temperature Cable not moved	-20 to 80	°C
Operating Temperature Cable moved	-5 to 80	°C
Storage Temperature	-30 to 80	°C

Handling & Assembly Instructions

- Max torque of nuts 1Nm
- Cable bending-radius is diameter x 15
- Min. bending distance to housing is 5mm
- Decrease switching distance by mounting on iron
- Do not use magnetically inductive screws
- Series resistor recommended for > 5m cable length

Layout

Top View

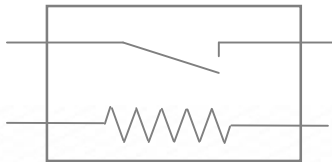

Life Test Data

*Load increase reduces life expectancy of Reed Switches

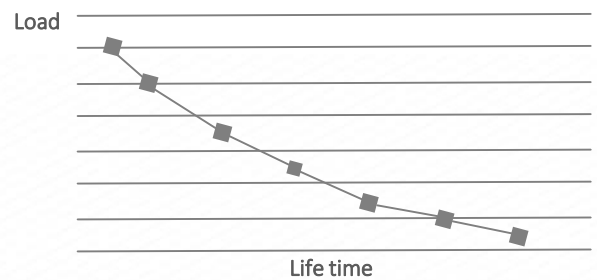

Glossary Magnetic Sensitivity

Sens.	A	B	C	D	E	F	G
AT	05-10	10-15	15-20	20-25	25-30	30-35	35-40

Please note: All technical specifications on this series datasheet refer to the standard product range. Modifications in the sense of technical progress are reserved. For general information only. For more specific information, please consult the product datasheet, available upon request.

This series datasheet could contain technical inaccuracies or typographical errors. Changes are periodically made to the information herein. These change will be incorporated in future revisions.

For deviating values, most current specifications and products please contact your nearest sales office.

