



# Winstar Display Co., LTD

## 華凌光電股份有限公司



WEB: <http://www.winstar.com.tw> E-mail: [winstar@winstar.com.tw](mailto:winstar@winstar.com.tw)

### SPECIFICATION

**MODULE NO.: WF52ASLASDNG0#**

### General Specifications

Item	Dimension	Unit
Size	5.2	inch
Dot Matrix	480 x RGBx128	dots
Module dimension	140.4 x 49.87 x 4.96	mm
Active area	127.152 x 33.9072	mm
Dot pitch	0.0883 x 0.2649	mm
LCD type	TFT, Normally White, Transmissive	
View Direction	6 o'clock	
Gray Scale Inversion Direction	12 o'clock	
Aspect Ratio	Bar Type	
Backlight Type	LED, Normally White	
Driver IC	ST7252 Or Equal	
Interface	RGB 24bit	
With /Without TP	With CTP	
Surface	Glare	

\*Color tone slight changed by temperature and driving voltage.

## Absolute Maximum Ratings

Item	Symbol	Min	Typ	Max	Unit
Operating Temperature	TOP	-20	—	+70	°C
Storage Temperature	TST	-30	—	+80	°C

## Electrical Characteristics

Item	Symbol	Condition	Min	Typ	Max	Unit
Supply Voltage For LCM	VCC	—	3.0	3.3	3.6	V
Supply Current For LCM	ICC	-	—	20	—	mA

# Interface

Pin	Symbol	Function
1	VLED-	Power for LED backlight cathode
2	VLED+	Power for LED backlight anode
3	GND	Power ground
4	VCC	Power voltage
5	R0	Red data (LSB)
6	R1	Red data
7	R2	Red data
8	R3	Red data
9	R4	Red data
10	R5	Red data
11	R6	Red data
12	R7	Red data (MSB)
13	G0	Green data (LSB)
14	G1	Green data
15	G2	Green data
16	G3	Green data
17	G4	Green data
18	G5	Green data
19	G6	Green data
20	G7	Green data (MSB)
21	B0	Blue data (LSB)
22	B1	Blue data
23	B2	Blue data
24	B3	Blue data
25	B4	Blue data
26	B5	Blue data
27	B6	Blue data
28	B7	Blue data (MSB)
29	GND	Power ground
30	CLK	Pixel clock (DCLK)
31	LR	Right /Left selection; Default R/L is Pull High
32	HSYNC	Horizontal sync signal; negative polarity
33	VSYNC	Vertical sync signal; negative polarity
34	NC	No connection
35	UD	Up/down selection; Default U/D is Pull High
36	RESET	Reset signal
37	NC	No connection
38	NC	No connection
39	NC	No connection
40	NC	No connection

# Contour Drawing

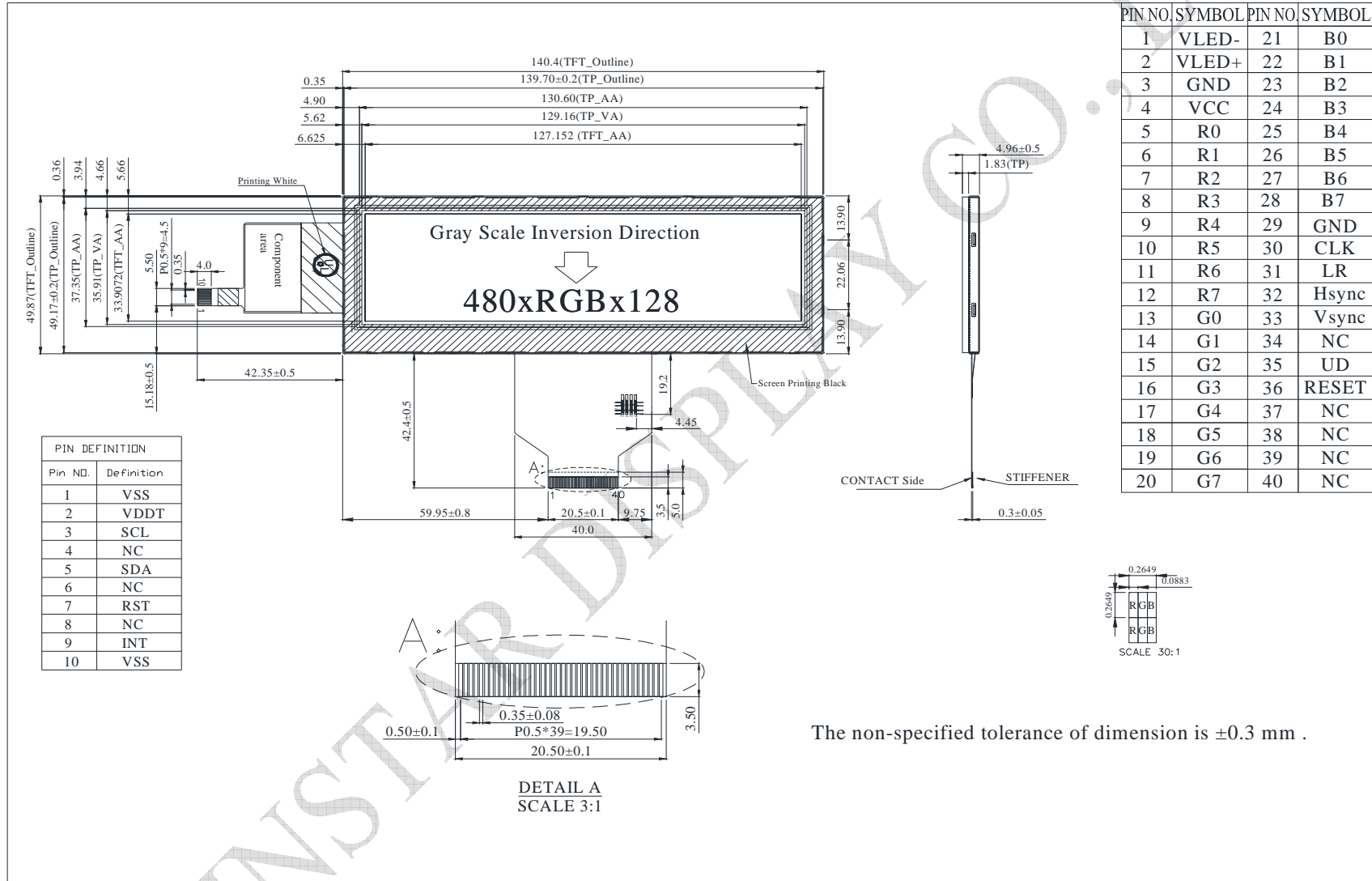

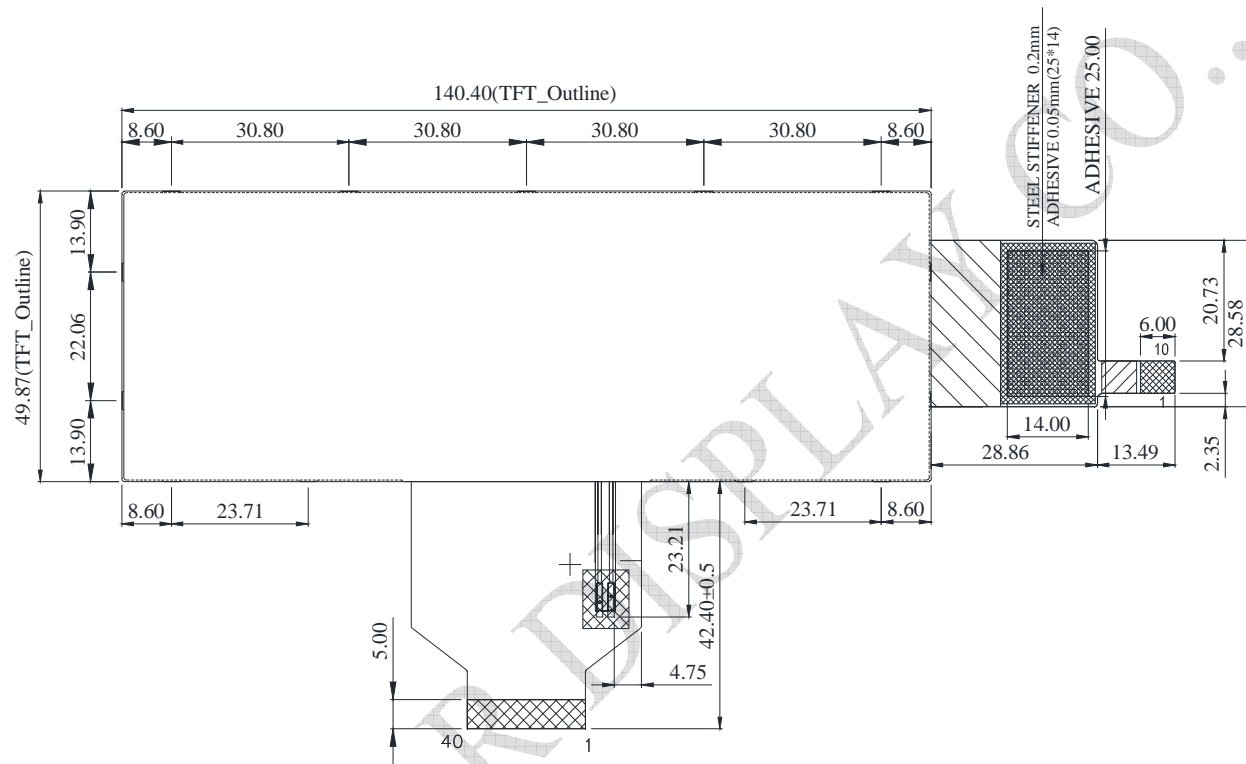

The non-specified tolerance of dimension is  $\pm 0.3$  mm .