

AC AXIAL FAN 120x120x38mm



Housing: Die-Cast Aluminum, Painted Black
 Blade: Thermoplastic PBT, UL 94V-0
 Insulation Resistance: 100MΩ, 500VDC/min between bare wire and frame
 Dielectric Strength: 1500VAC for one minute
 Operation Temperature: -10°C~70°C(Humidity 35%-85%RH)
 Storage Temperature: -40°C~85°C(Humidity 35%-85%RH)
 Motor Protection: Impedance Protected
 Weight: 560 g Packing: 40PCS/CTN



SS

Model Number	Voltage (VAC)	Frequency (Hz)	AirFlow (CFM)	Stat.Pres. (mm-H ₂ O)	Noise (dBA)	Speed (RPM)	Current (mA)	Power (W)	Available Bearing	Curves
FA1238B11T3-61	115	50/60	79.2/92.4	3.6/4.4	34.5/37.4	2,100/2,450	200/200	14/13	B,S	①/②
FA1238B11T5-61	115	50/60	92.4/101.5	6.3/7.1	38.4/41.4	2,450/2,700	250/250	19/17	B,S	③/④
FA1238B11T7-61	115	50/60	100.5/113.7	7.5/9.4	39.4/43.3	2,600/3,000	300/300	29/24	B,S	⑤/⑥
FA1238B22T3-61	230	50/60	79.2/92.4	3.6/4.4	34.5/37.4	2,100/2,450	100/100	12/11	B,S	①/②
FA1238B22T5-61	230	50/60	92.4/101.5	6.2/7.1	38.4/41.4	2,450/2,700	160/160	16/15	B,S	③/④
FA1238B22T7-61	230	50/60	100.5/113.7	7.5/9.4	39.4/43.3	2,600/3,000	200/200	28/24	B,S	⑤/⑥

- For "Sleeve" bearing version, change the "B" in the model number to "S".
- For "Wire Lead" version, change the "T" in the model number to "W".

Specifications are subject to change without notice

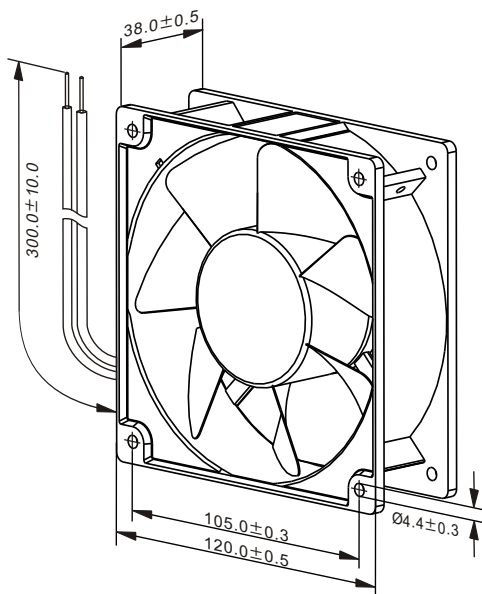

unit: mm

